

MICRON21 BUILDS WORLD-CLASS DATA CENTRE WITH A10 LOAD-BALANCING, SECURITY AND CLOUD SOLUTIONS

“ We have total confidence in moving forward and implementing the A10 Application Delivery Controllers (ADCs) as best-of-breed. These guys are serious, and their support is just as serious as their hardware. A10 Networks' equipment is the only choice in an extremely high-density environment, which fits our business model perfectly.”

James Braunegg | Managing Director, Micron21



CASE STUDY

COMPANY

Micron21 Datacentre Pty. Ltd.

INDUSTRY

Cloud and Hosting Provider

NETWORK SOLUTION

- Load balancing
- Traffic acceleration
- DDoS protection
- Cloud solution

CRITICAL ISSUES

- Vision to create world-class data centre
- Business expansion stressing infrastructure
- Urgent need for data acceleration and security

RESULTS

- Improved performance for traffic management and server offload
- Data centre efficiency with lower management overhead and operational costs
- Twice the performance of incumbent solutions, at half the cost
- Pay for services as they are consumed

Micron21's data centre in Melbourne, Australia, is home to thousands of clients representing hundreds of thousands of Internet websites and cloud services, including local, national and international businesses and government agencies. Micron21 delivers mission critical services via this fully redundant facility. The company's core business products include server co-location, virtual and physical dedicated servers, cloud services, high-performance web hosting, disaster recovery solutions, IP transit, Voice over IP (VoIP), local microwave and fibre services. Driven by increasing demand, Micron21 initiated a multi-million dollar facility upgrade that involved replacing every wall, floor, cable and infrastructure item with state-of-the-art technology. This data centre, with ample highly redundant and scalable infrastructure, proved itself to be world-class during Melbourne's 2014 White Night festival.

CHALLENGE

PREPARING TO HORIZONTALLY SCALE INFRASTRUCTURE INSTANTLY BY HAVING SPARE CAPACITY READY FOR ANY REQUIREMENT

Before the upgrade, Micron21 had been using software-based load-balancing technology with limited capabilities, and sought a more effective hardware solution. Shortly after implementing the A10 Networks appliances, Micron21 was given the opportunity to host the 2014 White Night festival. This event showcases Melbourne as Australia's international city of artistic innovation with a backdrop of art installations, live music, dance, design, film, sport and theatre performances. In order to provide concurrent access to more than 1 million simultaneous visitors who at any one time require instant access to event information via online communication for the duration of and lead up to the festival, technical staff relied heavily on A10 Networks ADCs to seamlessly manage load balancing, traffic acceleration and Distributed Denial of Service (DDoS) protection.

Micron21 knew it required reliable, high-performance devices with essential features such as RAM caching, compression, SSL acceleration and DDoS protection to successfully execute the festival's hosting and retain them as future clients.

SELECTION CRITERIA

PRICE/PERFORMANCE PLUS ALL INCLUSIVE LICENSING, AN EASY CHOICE

When Micron21 began searching for a more effective load-balancing solution, the chosen technology needed to meet extremely high standards. "We use a wide range of products from many different vendors, and always seek best-of-breed products offering the most effective combination of performance and reliability," said Braunegg. Other solutions considered were Brocade and F5, but they were quickly dismissed during the initial testing.

Although Braunegg acknowledged that A10 had not previously come to his attention, he felt the evaluation process proved to be a significant eye-opener to what a 1 RU ADC appliance could do. Describing what makes A10's ADCs an integral element in the company's data centre, Braunegg said, "[Micron21]...could make use of all of their features knowing they come at no additional cost."

Micron 21 chose A10 Networks ADCs for their flexibility and performance, with a capability of running 20 gigabits worth of load balance performance per device. "We bought four of them, giving us 80 gigabits of physical capacity, which was invaluable for us in supporting high-demand customers requiring on-demand services instantaneously," said Braunegg.

A virtual chassis system allows deployment of up to eight A10 appliances in a centrally managed system. The ADCs are logically placed closer to the edge of the network to provide DDoS protection, with capability to thwart up to 50 million SYN floods per second per appliance (using dedicated hardware ASICs).

A10's technology proved so effective that Micron21 also committed to becoming the first company globally to use A10 Networks Cloud Services solution in order to continue growing the business. The Cloud services architecture includes a portfolio of products and features that integrate with SDN network fabrics and cloud orchestration

platforms, dynamically delivering application and security services and policies per tenant for public, private or hybrid cloud deployments. With A10's Cloud services, cloud infrastructure-as-a-service (IaaS) operators can create a seamless integration of application networking services with the other data centre infrastructure to ensure appropriate service-level agreements (SLAs) and compliance. High-performance appliances provide the requisite capacity so that the key infrastructure services can scale to meet elastic demands, while a choice of form factor gives customers the flexibility to create a tailored offering in a high-density multi-tenant environment.

SOLUTION

PERFORMANCE LEVELS MADE A10 AN IDEAL FIT

The A10 Networks ADCs have exceeded Micron21's expectations every step of the way. According to Braunegg,

building network capacity to securely distribute content is only half of the equation; funneling traffic to multiple server appliances is the other. As he explains: "To load balance the inbound and outbound requests, we relied upon A10 Networks' hardware ADCs. Each has multiple 10 Gbps interfaces with 20 Gbps of throughput and the ability to communicate at over six million requests per second, per device. Configured as a high availability cluster, the A10 platform is extremely capable, while A10's dedicated Flexible Traffic Accelerator (FTA) technology processors provide extremely powerful real-time caching that greatly reduces server load capacity, sometimes in excess of 80 per cent."

RESULTS

The integration of A10 ADCs creates the horizontal scalability capacity in Micron21's environment, allowing additional parallel processing capacity to be added or removed seamlessly as required.

Braunegg said: "During the White Night festival, the Flexible Traffic Acceleration (FTA) processing capacity resulted in a load reduction of 80 per cent on each front end server from the native optimised software application stack, greatly reducing the number of front end servers required to distribute the load to the project target of more than a million visitors."

Before the event, he noted that the ADCs' performance levels made A10 an ideal fit for Micron21's ambitions. "The White Night event's success is further proof of A10 Networks' technology's capability. We have deployed multiple A10 ADCs, which have increased our data centre's efficiency while reducing management overhead and operational costs."

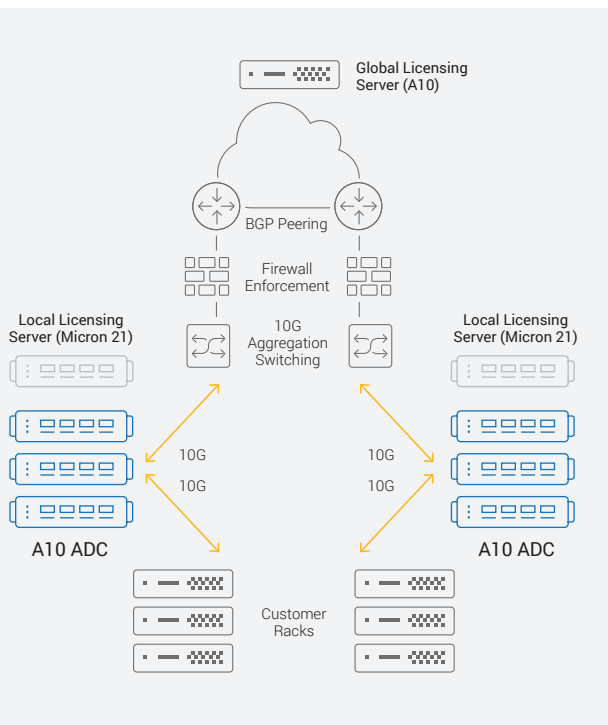

Figure 1: High-performance application delivery model

One set of ADCs is being used to provide Micron21 customers with advanced server load balancing and L4-L7 traffic acceleration. The others are delivering advanced DDoS protection.

Braunegg says the A10 cloud solution comprises a combination of ADC form factors and management tools that enable an elastic pay-as-you-grow environment and billing infrastructure. Micron21 is also leveraging the Cloud services architecture to optimise CapEx. A flexible licensing model enables cloud IaaS providers to provision virtual appliances up or down on demand, and offer a broader array of subscription services to their customers.

On-demand pay-as-you-go licensing models allow service providers to eliminate CapEx, and only pay for the services as they are consumed. As Braunegg says, "It allows us to create and generate a line of products where we can provide a load-balancing solution distributed across any of our sites. We can spin up a virtual instance within our cloud to provide dedicated cloud-based ADCs for both internal and external customers." The Cloud services architecture allows delivery of advanced L4-7 tenant services while improving agility and reducing total cost of ownership.

NEXT STEPS

LOAD BALANCING AND AUTOMATING THE CLOUD

Braunegg says Micron21 uses a wide range of products from many different vendors, seeking the best combination for performance and reliability. "The A10 appliances are our exclusive choice for load-balancing."

Services that meet the company's needs include dynamic routing, compression, RAM caching and SSL offload. "These services allow the backend web servers at Micron21 to run very efficiently, as the appliances are offloading much of the server performance demands."

These features are central to Micron21 becoming the first organisation globally to use A10's on-demand pay-as-you-go licensing infrastructure in its data centre. Micron21's launch of cloud-based application delivery services takes advantage of the solution's premium feature set for future revenue growth. The on-demand licensing model allows Micron21 to offer and deliver advanced L4-7 and networking tenant services with automated metering, reporting, billing and license management. The licensing model enables cloud IaaS operators to offer on-demand application networking services to their customers on a subscription basis, similar to the way they offer compute and storage services.

For data centre operators seeking excellence, Braunegg has straightforward advice: "Take the chance and go with A10! Based on initial successes, now reconfirmed by the White Night event, we have total confidence in moving forward and implementing these boxes as best-of-breed. These guys [A10 Networks] are serious, and their support is just as serious as their hardware. A10 Networks' equipment is the only choice in an extremely high-density environment, which fits our business model perfectly."

For data centre operators seeking excellence, Braunegg has straightforward advice: "Take the chance and go with A10! Based on initial successes, now reconfirmed by the White Night event, we have total confidence in moving forward and implementing these boxes as best-of-breed."

ABOUT MICRON21

Micron21 delivers mission critical services by controlling and owning a world class fully redundant data centre facility in Melbourne, Australia. The company's core business products include: server co-location, virtual and physical dedicated servers, cloud services, high-performance web hosting, disaster recovery solutions, IP transit, VoIP, local microwave and fibre services. Micron21's data centre is home to thousands of direct clients representing hundreds of thousands of Internet websites and cloud services, including local, national and international businesses and government agencies. Clients include Nissan Australia, Subway and Anaconda, as well as universities and government departments.

ABOUT A10 NETWORKS

A10 Networks (NYSE: ATEN) is a Secure Application Services™ company, providing a range of high-performance application networking solutions that help organizations ensure that their data center applications and networks remain highly available, accelerated and secure. Founded in 2004, A10 Networks is based in San Jose, Calif., and serves customers globally with offices worldwide.

For more information, visit: a10networks.com or tweet [@A10Networks](https://twitter.com/A10Networks).

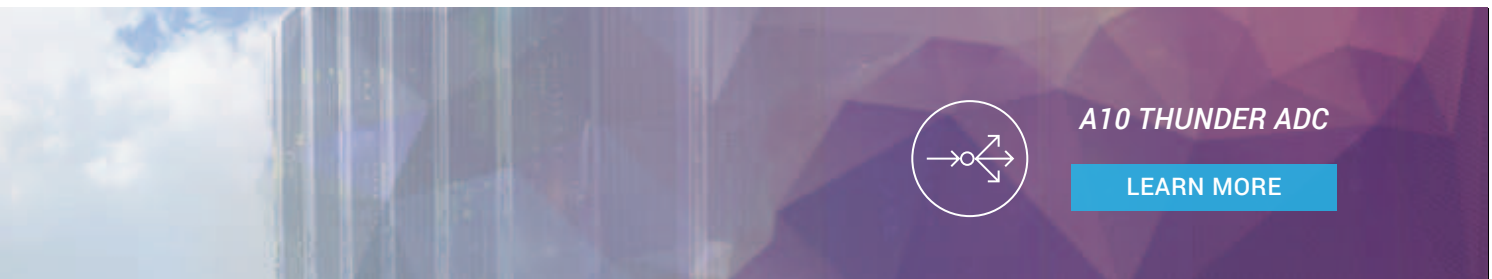

LEARN MORE
ABOUT A10 NETWORKS

[CONTACT US](http://a10networks.com/contact)
a10networks.com/contact

©2017 A10 Networks, Inc. All rights reserved. A10 Networks, the A10 Networks logo, ACOS, Thunder, Lightning, Harmony and SSL Insight are trademarks or registered trademarks of A10 Networks, Inc. in the United States and other countries. All other trademarks are property of their respective owners. A10 Networks assumes no responsibility for any inaccuracies in this document. A10 Networks reserves the right to change, modify, transfer, or otherwise revise this publication without notice. For the full list of trademarks, visit: www.a10networks.com/a10-trademarks.

Part Number: A10-CS-80111-EN-03 OCT 2017