



# YAHOO! JAPAN

# + A10 Networks

## With AX Series, Yahoo! JAPAN Can Handle Peak Traffic with Space and Energy Efficiency

Yahoo Japan Corporation was established in 1996 to provide information search services online. Based on its corporate philosophy of "Yahoo! JAPAN, for anything, anywhere", the corporation aims to provide a rich, convenient and valuable "Life Engine". A10 Networks' AX Series was chosen to strengthen the network infrastructure of Yahoo Japan services.



**52.16**  
Billion  
Page Views  
Monthly Total Internet Page Views

**10.96**  
Billion  
Page Views  
Monthly Page Views for Yahoo! Mobile

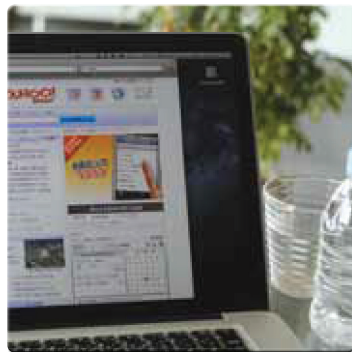

**25.76**  
Million IDs  
**7.75** Million  
IDs  
Monthly Active User ID Count  
Yahoo! Premium Member Monthly ID Count



**200**  
Million  
Browsers  
Monthly Unique Browser Count



**20,625**  
Stores  
**73.7** Billion  
Yen  
Yahoo! Shopping Store Count (Quarter Total)  
Yahoo! Shopping Store Sales (Quarter Total)



**17,542**  
Stores  
**161.1** Billion  
Yen  
Yahoo! Auction Store Counts (Quarter Total)  
Yahoo! Auction Trading Volume (Quarter Total)



**Challenges**

**Load Balancer Cannot Handle the Stress of Peak Load**

Yahoo Japan Corporation (Yahoo) operates Internet information search service "Yahoo! JAPAN," which provides over 150 services for shopping and news (as of November 2011). With its active user counts of 25.76 million and 52.16 billion page views (as of September 2011), suspension due to system errors or deterioration due to access spikes can directly affect corporate sales or share value. As such, maintenance of fast and stable network infrastructure is required.

However, with increased access from mobile phones and smartphones as well as PCs, it has faced challenges for handling stress on load balancers under peak load.



A10 Networks, AX Series

"Not only limited to Yahoo! JAPAN, the current Internet environment sees the increase in services with motion graphics. As a result, connection and reload counts are increasing especially when events such as sports games take place. In particular, high traffic during lunch hours puts significant load on the network," says Nobuhiro Takasawa, Network Operations1 Leader.

At Yahoo, the maximum traffic and the maximum past connection counts are recorded to always maintain sufficient specifications to handle required peak load.

"Implementation of high performance load balancers was required for high-spec web servers and application servers to handle expected traffic gains," says Mr. Takasawa.

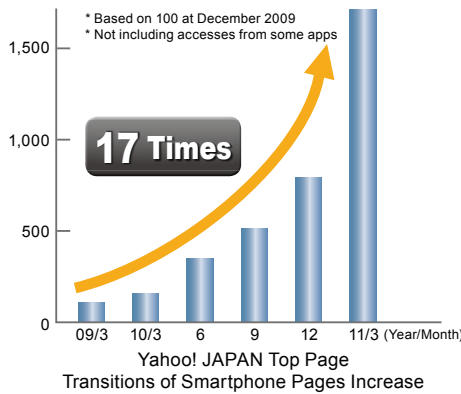

**On Test**

**AX Series Implemented Based on Its Architecture**

Yahoo, during summer 2008, began considerations for implementing new load balancers. Through testing and comparisons of various products, AX Series from A10 Networks was selected as the product of choice.

Following November 2009, the company started operations for AX Series implementation and full-blown AX utilization began in January 2010.

64-bit AX Series products with higher scalability were then added to the mix as of summer 2010. "We were considering a 64-bit network environment since servers are

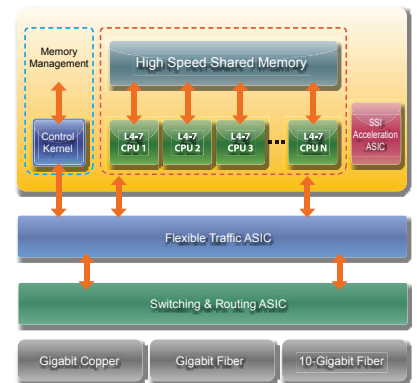

ACOS Architecture

**About Yahoo! JAPAN**

Yahoo Japan Corporation  
The First Section of the Tokyo Stock Exchange/ JASDAQ  
Security Code: 4689  
Located: Minato-ward, Tokyo  
Established: 31st January 1996  
Company Representative: Manabu Miyasaka  
Areas of Business: Internet advertisement, e-commerce, membership services, and other Internet services.

**Evaluation Point**



**Intuitive Platform with High Scalability**

Yahoo Japan Corporation  
**Nobuhiro Takasawa**  
Network Operations1 Leader

"AX Series was implemented based on its architecture and system configuration meeting our requirements. We highly value A10's ACOS architecture, which includes FTAs (flexible traffic ASICs), allowing processing of Layer 4 and above with plenty of CPU power.

A10's ACOS architecture is a platform with high scalability. Also, we are very pleased with the support we receive from A10 and its sales partners."



constantly becoming 64-bit. AX's 64-bit platform definitely has high possibilities and we like to continue to test new technologies," says Mr. Takasawa. The company implemented AX's GSLB (Global Server Load Balancing) feature for the purpose of service infrastructure disaster recovery.

"Furthermore, in our network environment for internal systems, AX is in operation in tandem with Exchange servers and other operation systems." After reviewing AX Series for over a year, Miyuki Tsunekawa, Network Engineer says, "In our testing environment, various analysis were carried out on basic functional load balancing requirements, and AX Series functionality was highly satisfactory."

"Furthermore, when we requested additional development of Yahoo's original features needed for our operations, the support we received through the coordination of A10 and its sales partners was very good, and projects were performed flexibly and promptly. So, we quickly soon verified the features, confirmed that they had no issues, and deployed them into operation. As for set-up, intuitive interfaces are provided so that we faced no major problems with the implementation."



## High-performance, Space-saving, and Energy-efficient: an Effective AX Series Implementation

Mr. Takasawa said, "We do not need to worry about CPU load at all. With the first 32-bit AX, there was some level of strain under peak load but we have never experienced any impact with the 64-bit AX. There is an apparent reduction of space and energy consumption in our data center."

Mr. Takasawa also added, "From the various functions of load balancing, we sometimes want to use features immediately. With competing products, licensing prohibition may



Image of GSLB Disaster Recovery

limit the immediate use of some features, while the AX includes all features with the initial purchase, without licensing fees. So it is extremely convenient that any feature can be enabled at will. Also, inter-office traffic flow is constantly changing and future configuration changes may be necessary. In any case, we have high hopes for the AX Series."

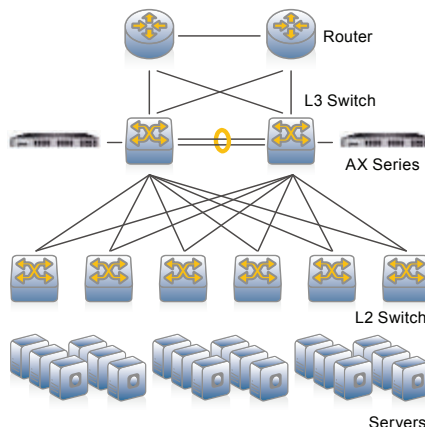

Network Configuration Diagram

### Evaluation Point



### Realization of Yahoo Japan Corporation's Advanced Technical Abilities

A10 Networks, K.K.  
Sales Department General Manager  
**Hiroyuki Yatabe**

This case study's implementation is genuinely based upon the correct evaluation of product functionalities rather than manufacturer brand or market recognition. We felt the advanced technical abilities of Yahoo Japan Corporation led to unbiased judgments and evaluations of AX Series solutions. We are pleased to be able to provide operability for Yahoo's

extensive traffic. We have increased our brand and market share thanks to this experience.

### About AX Series

A10's AX Series is a scalable, high-performance Application Networking platform that delivers enterprises, Web properties and ISPs superior reliability and an energy efficient footprint for lower total cost of ownership (TCO). With the AX Series, customers of all sizes benefit from application availability, scalability & performance; increased infrastructure efficiency and a faster end user experience.

The AX Series has a comprehensive Layer 4-7 feature set and flexible virtualization technologies such as Virtual Chassis System (aVCS), multi-tenancy and more for public, private and hybrid cloud environments. In addition, the AX Series leads in IPv6 Migration technologies with many large scale deployments worldwide.

AX Series delivers industry-leading return on investment (ROI) by leveraging A10's 64-bit Advanced Core OS (ACOS), with a scalable shared-memory architecture that leaps the competition in scalability and flexibility.

Please refer to the following website for more information: <http://www.a10networks.com/>

" We have peace of mind with A10's proven IPv6 and virtualization solutions."



Miyuki Tsunekawa

Miyuki Tsunekawa

Network Engineer, Yahoo Japan Corporation

" With AX Series, all features are included without licensing fees."



Satoshi Tenda

Satoshi Tenda

A10 Networks, K.K.  
Technical Department, Japan and South Asia General Manager

## Comprehensive IPv6 and Virtualization Solution

This case study includes an interview between Yahoo Japan Corporation, one of Japan's largest information search service providers, and A10 Networks, a leading innovator in Application Delivery. A10's Satoshi Tenda discusses with Yahoo's Miyuki Tsunekawa the two companies' approaches to networking industry trends, such as Virtualization, IPv6, and GSLB (Global Server Load Balancing), as well as some future plans.

### Network Virtualization Commanding Attention

**Tenda (Te):** Network virtualization is becoming more and more common. Could you tell me about how it is progressing at Yahoo?

**Tsunekawa (Ts):** Compared to server virtualization, network virtualization can present greater challenges to overcome, but it is considered to be an effective technology.

**Te:** As a part of virtualization technology, A10 is currently providing ADPs (Application Delivery Partitions), a technique to enable consolidation of multi-device configuration. Any plans for Yahoo?

**Ts:** We are definitely interested in network virtualization. It is only that our system is not quite ready for aggressive implementation just yet. However, I would like to see ADP utilization to realize a system to

consolidate different configurations such as DSR (Direct Server Return) and inline.

### Established IPv4-IPv6 Interoperation

**Te:** We note that Yahoo is already utilizing IPv6. Do you see a level of increase in IPv6 traffic?

**Ts:** I cannot go too much into detail due to company strategy, but I can tell you that we do support both IPv4 and IPv6. With IPv6, it is a little difficult to read the addresses, but apart from that, I do not feel any resistance to speak of. We have plans to implement IPv6 L3 DSR, and actively support IPv6 GSLB in particular.

At the same time, we are also reviewing IPv6 as well as virtualization, and as a result, we have a feeling that both can be utilized with AX Series without any problem. Now there is a sense of assurance for the full-blown implementation of IPv6 and virtualization.

### Forming Multi-location DR with GSLB

**Te:** We note your plans for reducing downtime through disaster recovery (DR) with GSLB. Can you provide your opinion on

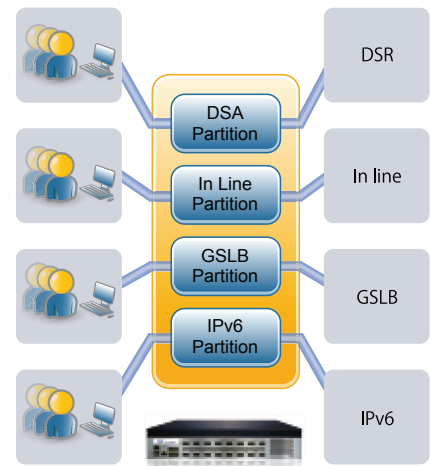

Impression of ADP Consolidation

your future Business Continuity Plan (BCP)?

**Ts:** DR utilizing GSLB is already configured and in operation at multiple locations. Since any suspension of service can directly lead to loss of business, we would like to actively propel implementation including redundancy of our data center.

**Te:** It is possible to distribute data in such a way that it allows locations and utilization situations to be accounted for. Accesses from Tokyo transferred to Tokyo and the ones from Osaka are made to go to Osaka for example, which could result in higher quality of service.

**Ts:** Perhaps not all can be realized straight away but we are preparing for the future implementation. We definitely have high expectations for your support.

**Te:** Thank you. We will continue to provide useful solutions, and we look forward to a long and prosperous business relationship.



**A10 Networks, Inc.**

3 West Plumeria Drive, San Jose, CA 95134

Tel: +1 408 325-8668 Fax: +1 408 325-8666 www.a10networks.com

**Customer Driven Innovation**

© 2012 A10 Networks, Inc. All rights reserved #CSAX\_20111221\_yahoo